



# AQUAMINI

## POOL HEAT PUMP



USERMANUAL

## Table of contents

<b>A. Foreword</b>	3
<b>B. Safety precautions</b>	4
1. Warning	4
2. Attention	5
3. Safety	5
<b>C. About your heat pump</b>	6
1. Transportation	6
2. Accessories:	6
3. Operating condition and range:	6
4. Technical parameter	7
5. Dimension	8
<b>D. Installation guidance</b>	9
1. Installation reminder	9
2. Wiring	10
3. Reference for protecting devices and cable specification	10
<b>E. Testing</b>	11
1. Inspect heat pump before use	11
2. Leakage detection notice and method	11
3. Trial	11
4. condensate water	11
<b>F. Operation guidance</b>	12
1. Key function	12
2. Temperature display	12
3. Operation instruction	12
a. Turn on/off	12
<b>G. Maintenance</b>	13
<b>H. Trouble shooting for common faults</b>	13

## **A. Foreword**

Thank you for choosing our pool heat pump, which is designed for more silent and energy saving user experience. It is an ideal way for green pool heating.

We hope you'll enjoy using our heat pumps.

Thank you!

## B. Safety precautions





We have provided important safety messages in this manual and on your heat pump. Please always read and obey all safety messages.

**This heat pump uses eco-friendly R32 refrigerant gas**

### 1. Warning



The WARNING sign denotes a hazard. It calls attention to a procedure, practice, or the like, which, if not correctly performed or adhered to, could result in personal injury or injury to a third party. These signs are rare, but are extremely important.

	a. Keep the heat pump away from fire source.
	b. It must be placed in well ventilated area, indoor or closed area is not allowed.
	c. Repair and disposal must be carried out by trained service personnel
	d. Vacuumize completely before welding. Welding can only be carried out by professional personnel in service center.

## **2. Attention**

- a. Please read the following instructions before installation, use and maintenance.
- b. Installation must be done by professional staff only in accordance with this manual.
- c. Leakage test must be performed after installation.
- d. Please don't stack substances, which will block air flow near inlet or outlet area, otherwise the efficiency of the heater will be reduced or even stopped.
- e. Set proper temperature in order to get comfortable water temperature to avoid overheating or overcooling.
- f. In order to optimize the heating effect, please install heat preservation insulation on pipes between swimming pool and the heat pump, and please use a recommended cover on the swimming pool.
- g. Connecting pipes of the swimming pool and the heater should be  $\leq 10\text{m}$ .
- h. Except for the methods recommended by the manufacturer, do not use any methods to accelerate the defrosting process or clean the frosted parts.
- i. If a repair is required, please contact the nearest after-sales service center. The repair process must be strictly in accordance with manual. All repair practice by non-professional is prohibited.
- j. Don't use or stock combustible gas or liquid such as thinners, paint and fuel to avoid fire.

## **3. Safety**

- a. Please keep the main power supply switch far away from the children.
- b. When a power cut happens during operating, and later the power is restored, the heater will start up.
- c. Please switch off the main power supply in lightning and storm weather to prevent from machine damage that caused by lightning;
- d. To reduce the safety risk, a safety check should be done before maintenance or repair.
- e. Any repairing should be conducted in the area with good ventilation. The ignition source is prohibited during the inspection.
- f. If a leakage of refrigerant gas happens, all operation must be stop and call for emergency service immediately.

## C. About your heat pump

### 1. Transportation

a. Always keep upright

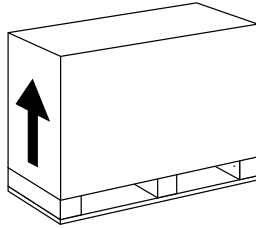

b. Do not lift the water union  
(Otherwise, the titanium heat exchanger inside the heat pump may be damaged)

### 2. Accessories:

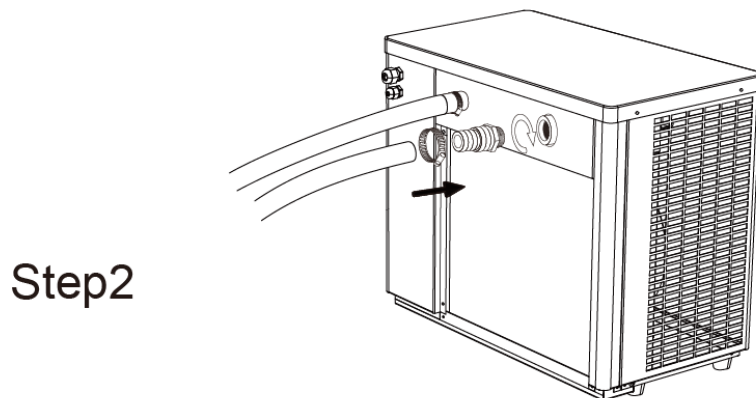
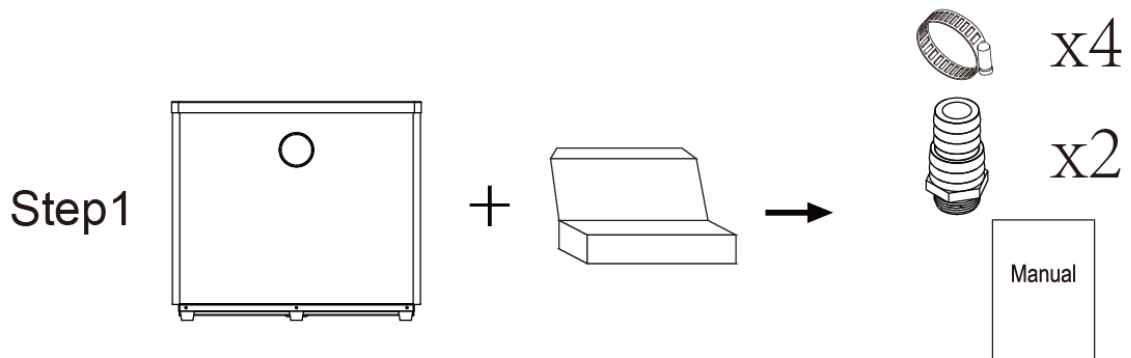

### 3. Operating condition and range:

The heat pump will have ideal performance in the operation range Air 10°C ~ 43°C

#### 4. Technical parameter

Model	XS04	XS06	XS08
<b>PERFORMANCE CONDITION: Air 27°C/ Water 27°C/ Humid. 80%</b>			
Heating capacity (kW)	3.5	5.6	7.7
COP	5	5.1	5.3
<b>PERFORMANCE CONDITION: Air 15°C/ Water 26°C/ Humid. 70%</b>			
Heating capacity (kW)	2.3	4.0	5.4
COP	4.0	4.1	4.3
<b>TECHNICAL SPECIFICATIONS</b>			
Advised pool volume (m <sup>3</sup> ) *	0~12	5~20	10~35
Operating air temperature (°C)	10°C~43°C		
Rated input power (kW)	0.58	0.98	1.26
Rated input current (A)	2.5	4.2	5.5
Sound level at 10m dB(A)	26	27	28
Advised water flux (m <sup>3</sup> /h)	1~2	2~2.5	2.5~3.5
Water connection (mm)	32/38		

#### Remarks:

This heat pump is able to perform normal within air temp 10°C~+43°C, efficiency will not be guaranteed out of this range. Please take into consideration that the pool heat pump performance and parameters are different under various conditions.

Related parameters are subject to adjustment periodically for technical improvement without further notice. For details please refer to nameplate.

## 5. Dimension

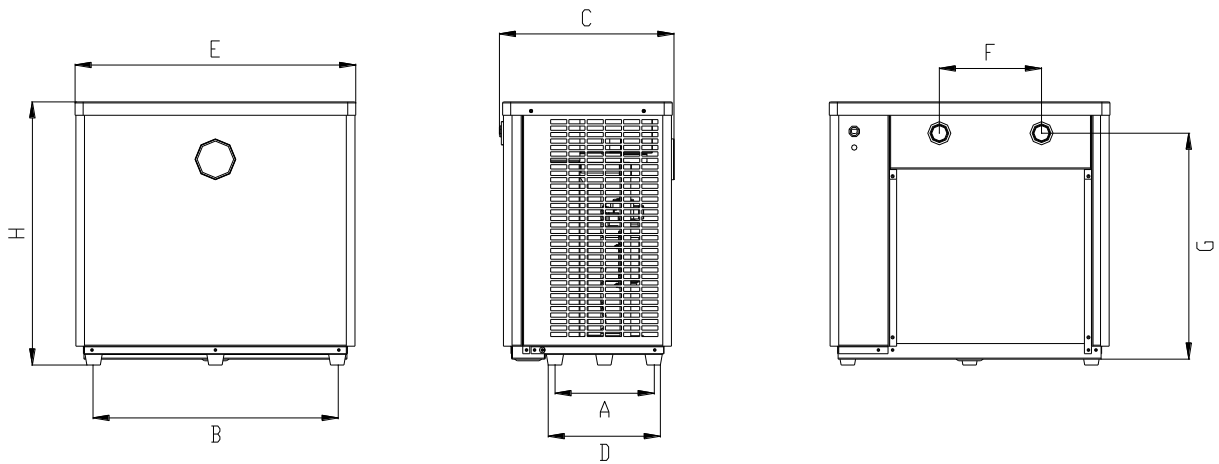

Size (mm) Name	A	B	C	D	E	F	G	H
Model								
<b>XS04</b>	184	457	316	209	523	190	421	490
<b>XS06</b>	184	634	316	209	703	280	421	490
<b>XS08</b>	184	644	316	209	713	300	571	640

※ Above data is subject to modification without notice.

Note: The picture above is the specification diagram of the pool heater, for technician's installation and layout reference only. The product is subject to adjustment periodically for improvement without further notice.



## D. Installation guidance

### 1. Installation reminder

Attention:

- a. Any chemical products should be added in outlet tube of heatpump, even it doesn't enter the heatpump.
- b. Location and dimension



The pool heat pump should be installed in a good ventilation place, with stable power supply and filter. The distance between heat pump and other objects like wall, bush or devices should be at least **50 cm**, the distance between heat pump and the pool should be atleast **2 meters**. For indoor pool, please consult the installation technician.

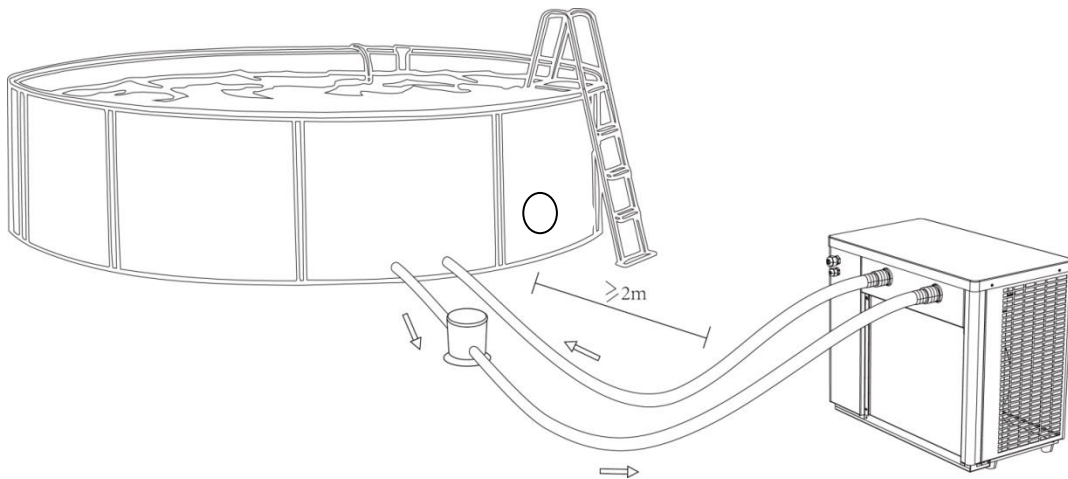

- 1) The frame must be fixed by bolts (M10) to concrete foundation or brackets. The concrete foundation must be solid and fastened; the bracket must be strong enough and antirust treated;
  - 2) Please don't stack substances that will block air flow near inlet or outlet area, and there is no barrier within 50cm behind the main machine, or the efficiency of the heater will be reduced or even stopped;
  - 3) The machine needs an appended pump (Supplied by the user). The recommended pump specification-flux: refer to Technical Parameter, Max. lift  $\geq 10\text{m}$ ;
  - 4) When the machine is running, there will be condensation water discharged from the bottom, please pay attention to it. Please hold the drainage nozzle (accessory) into the hole and clip it well, and then connect a pipe to drain the condensation water out.
- c. To use the machine, please make sure follow the order:  
Open water pump → Open heat pump  
Close heat pump → Close water pump

## 2. Wiring

- Connect to appropriate power supply, the voltage should comply with the rated voltage of the products.
- Earth the machine well.
- Wiring must be handled by a professional technician according to the circuit diagram.
- Set leakage protector according to the local code for wiring (leakage operating current  $\leq 30\text{mA}$ ).
- The layout of power cable and signal cable should be orderly and not affecting each other.

## 3. Reference for protecting devices and cable specification

MODEL		XS04	XS06	XS08
Breaker	Rated Current (A)	4.5	8.0	9.0
	Rated Residual Action Current (mA)	30	30	30
Fuse(A)		4.5	8.0	9.0
Power Cord(mm <sup>2</sup> )		3x1.5	3x1.5	3x1.5
Signal Cable(mm <sup>2</sup> )		3x0.5	3x0.5	3x0.5
R32 Gas Weight (g)		250	460	550

※ Above data is subject to modification without notice.

**Note:** The above data is adapted to power cord  $\leq 10\text{m}$ . If power cord is  $> 10\text{m}$ , wire diameter must be increased.

### Attention:

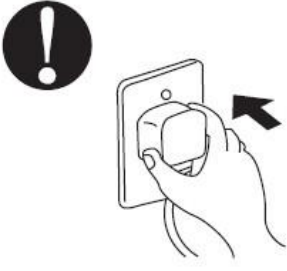
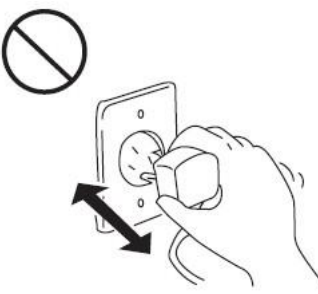
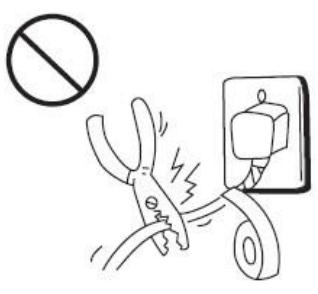
<p><b>Make sure the plug is not damaged</b> If the plug is not safe, it might cause electric attack, over heat, or fire</p> 	<p><b>Do not pull out the plug when it's functioning</b> It might cause electric attack, over heat, or fire</p> 	<p><b>Do not use damaged or inappropriate wire</b> It might cause electric attack, over heat, or fire</p> 
---	---	---

## E. Testing

### 1. Inspect heat pump before use

- a. The ventilating device and outlets are operating adequately and are not obstructed.
- b. It's prohibited to install refrigeration pipe or components in corrosive environment.
- c. Inspect the electric wiring on basis of the electric wiring diagram and earthing connection.
- d. Double confirm the main machine power switch should be off.
- e. Inspect the air inlet and outlet.

### 2. Leakage detection notice and method



- a. Leakage checking is prohibited in closed area.
- b. The ignition source is prohibited during the leakage inspection. A halide torch (or any other detector using a naked flame) shall not be used.
- c. Leakage detection fluids can be applied with most refrigerants but the use of detergents containing chlorine shall be avoided as the chlorine may react with the refrigerant and corrode the copper pipe.
- d. Vacuumize completely before welding. Welding can only be carried out by professional personnel in service center.
- e. Please stop using while gas leakage occur, and contact professional personnel in service center.

### 3. Trial

- a. The user must "Start the Pump before the Machine, and Turn off the Machine before the Pump", or the machine will be damaged.
- b. Before start the heat pump, please check for any leakage of water.
- c. In order to protect the swimming pool heater, the machine is equipped with a time lag starting function, the fan will run 1 minute earlier than the compressor when starting the machine, and it will stop running 1 minute later than the compressor when power off the machine.
- d. After the swimming pool heater start up, please kindly checking for any abnormal noise from the machine.

### 4. condensate water

It might have condensate water on evaporator, especially in an humid environment, it could have liters of water, sometimes it will be mistaken as a leakage

## F. Operation guidance

### 1. Key function



Symbol	Designation	Function
	ON/OFF	Power On/Off
	UP/DOWN	Temperature Setting From 18~40°C

### 2. Temperature display

Celsius degree display:



means 28°C

### 3. Operation instruction

a. Turn on/off

Press to turn on/off the machine

b. Temperature Setting

When the machine is on, press and to set temperature.

### 4. Defrosting

Automatic defrosting: When machine is auto defrosting, "☀" will flash, and return to previous working mode when it finishes.

(Remarks: the interval between forced defrosting should be more than 30 minutes.)

## G. Maintenance



**“CUT OFF” power supply of the heat pump before cleaning, examination and repairing**

1. In winter season when you don't swim:
  - a. Cut off power supply to prevent any machine damage.
  - b. Drain water clear of the machine.
  - c. Cover the machine body when not in use.



**!!Important:**

Unscrew the water nozzle of inlet pipe to let the water flow out.  
*When the water in machine freezes in winter season, the titanium heat exchanger may be damaged.*

2. Please clean this machine with household detergents or clean water, NEVER use gasoline, thinners or any similar fuel.
3. Check bolts, cables and connections regularly.
4. If repair or scrap is required, please contact authorized service center nearby.
5. Do not attempt to work on the equipment by yourself. Improper operation may cause danger.

## H. Trouble shooting for common faults

### 1. Repairing Guidance

---



**WARNING:**

- a. If repair or scrap is required, please contact authorized service center nearby.
- b. Requirements for Service Personnel
- c. Any person who is involved with working on or breaking into a refrigerant circuit should hold a current valid certificate from an industry-accredited assessment authority, which authorizes their competence to handle refrigerants safely in accordance with an industry recognized assessment specification.
- d. Do not attempt to work on the equipment by yourself. Improper operation may cause danger.

- e. Strictly comply with the manufacturer's requirements when charging R32 gas and equipment maintenance. This chapter focuses on special maintenance requirements for swimming pool heat pump with R32 gas. Please refer to the technical service manual for detailed maintenance operation.
- f. Vacuumize completely before welding. Welding can only be carried out by professional personnel in service center.

## 2. Failure solution and code

Failure	Reason	Solution
<b>Heat pump doesn't run</b>	No power	Wait until the power recovers
	Power switch is off	Switch on the power
	Fuse burned	Check and change the fuse
	The breaker is off	Check and turn on the breaker
<b>Fan running but with insufficient heating</b>	evaporator blocked	Remove the obstacles
	Air outlet blocked	Remove the obstacles
	3 minutes start delay	Wait patiently
<b>Display normal, but no heating</b>	Set temp. too low	Set proper heating temp.
	3 minutes start delay	Wait patiently
If above solutions don't work, please contact your installer with detailed information and your model number. Don't try to repair it yourself.		

**Note:** If the following conditions happen, please stop the machine immediately, and cut off the power supply immediately, then contact your dealer:

1. Inaccurate switch action.
2. The fuse is frequently broken or leakage circuit breaker jumped.

## 3. Error code

Error code	Description
PP1	Inlet water temperature sensor malfunction
PP2	AIN2 connected temperature sensor malfunction
PP3	AIN3 connected temperature sensor malfunction
PP4	Gas return temp sensor malfunction
PP5	Environment temperature sensor malfunction
PP7	Over low temperature of environment
EE1	Overhighpressure protection
EE2	Over low pressure protection
EE3	Water flux switch malfunction



